

This drawing is the sole property of Miether Bearing Products and contains confidential and proprietary information. It is being provided to you for your use and may not be disclosed to any third party or used for any other purpose without Miether's prior written consent. The [materials] must be returned to the Company upon its demand. Your acceptance of these materials constitutes your acceptance of the foregoing terms.

C-35315

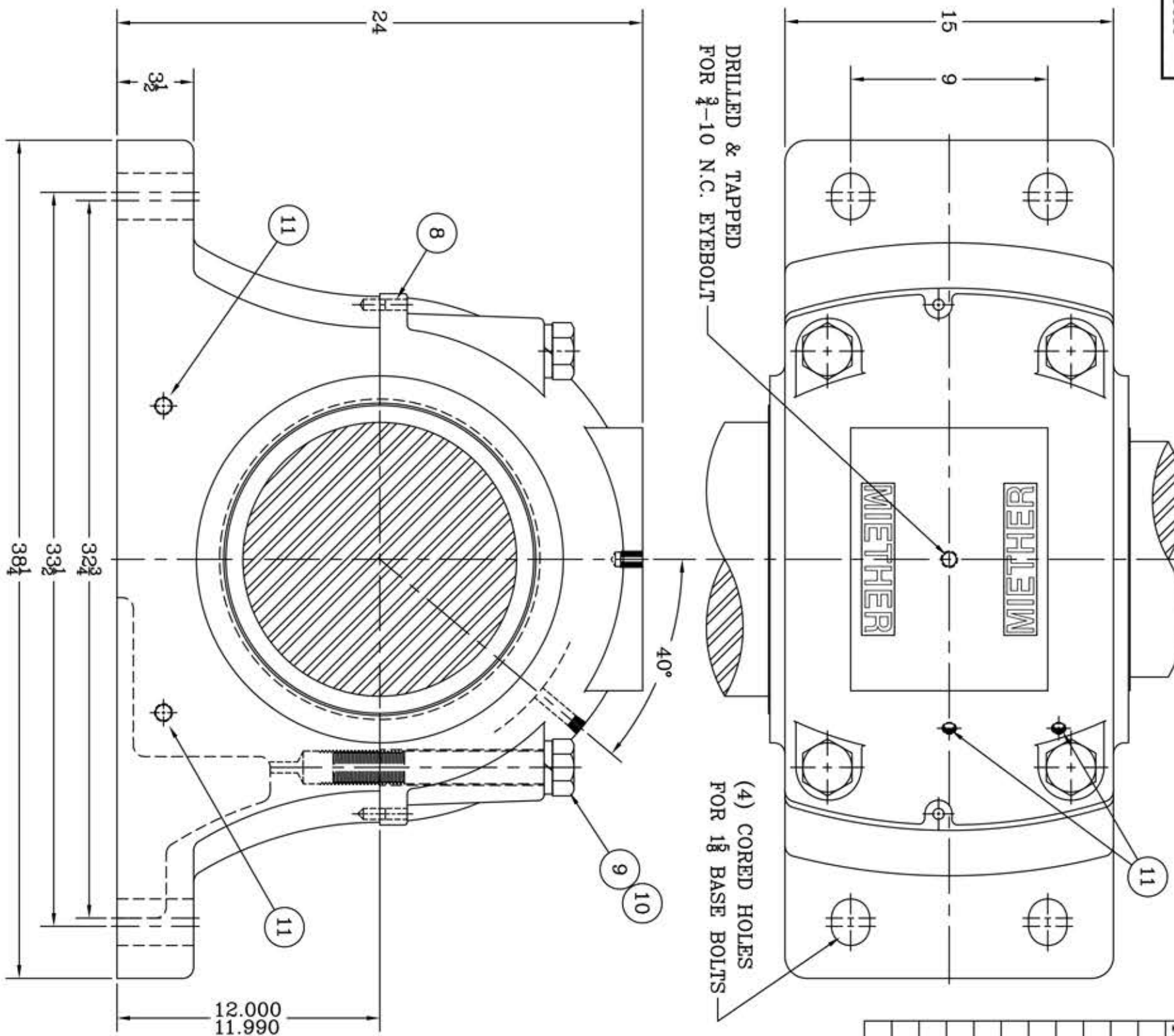

DRILLED & TAPPED FOR 3/4-10 N.C. EYEBOLT

(4) CORED HOLES FOR 1/8 BASE BOLTS

ITEM	DESCRIPTION	DETAIL	REQUIRED
1	HOUSING SDAFD 3256	C-	1 1
2	SPHERICAL ROLLER BEARING 23256/W33		1 1
3	STABILIZING RING A8975	A-12809	2 0
4	LOCKNUT NO-56	B-10050	1 1
5	LOCKWASHER P-56	A-10154	1 1
6	TRIPLE SEAL RING ER-826	A-15991	1 1
7	TRIPLE SEAL RING ER-866	A-11299	1 1
8	DOWEL 1/2 x 1" LONG		2 2
9	CAP BOLT HEX. HEAD GR.5 1 1/2-6 NC x 10" LONG		4 4
10	LOCKWASHER 1 1/2 SPLIT MED.		4 4
11	PIPE PLUG 3/8-18 NPT		5 5

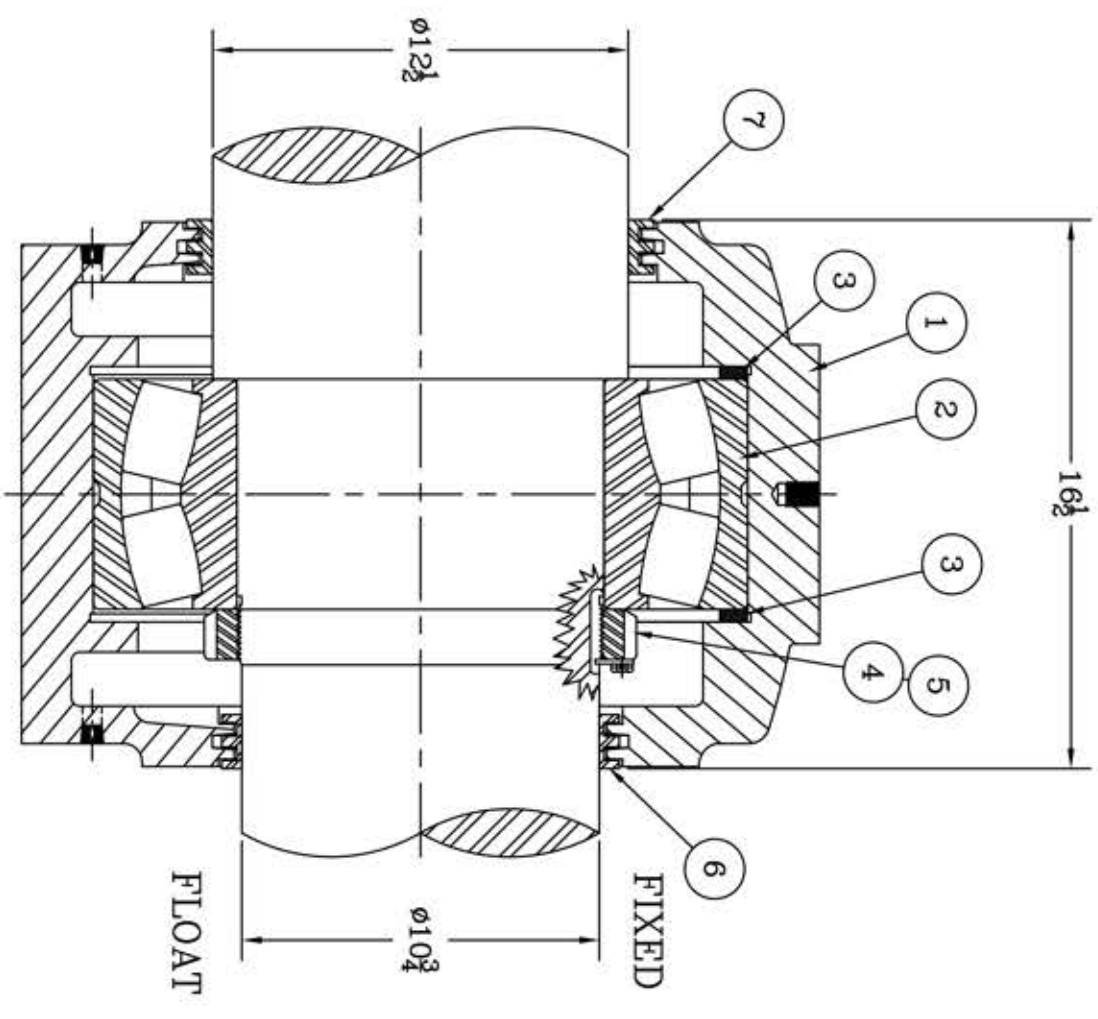

HOUSING MATERIAL - DUCTILE IRON  
ASTM A536 GR 65-45-12

REVISIONS

SYMBOL	DESCRIPTION						
16	18	32	63	125	250	500	1000

TOLERANCE: UNLESS OTHERWISE SPECIFIED  
FRACTIONS +- 1/32" ANGLES +- 0° 30'  
DECIMALS +- .005" WELD +- 1/16"  
CASTING +- 1/16"

A.I.S.I. STANDARD FINISHES

AN ALCO INDUSTRIES COMPANY  
BEARING PRODUCTS  
ODDESSA, TX. USA

SDAFD 23256 12-08 x 10-12  
ASSEMBLY DRAWING

SCALE 1 = 4  
DRAWN PCF  
DATE 1/10/13  
CHK:

ASSEMBLY NO.  
DRAWING NO.  
C-35315